



AS Level Physics

Chapter 3 – Forces and Motions

3.6.2 Density and Pressure

Worked Examples

DENSITY

Exam Style Question 1:

- a) Define density.
- b) Fig. 2.1 shows the variation of density of the Earth with depth from the surface.

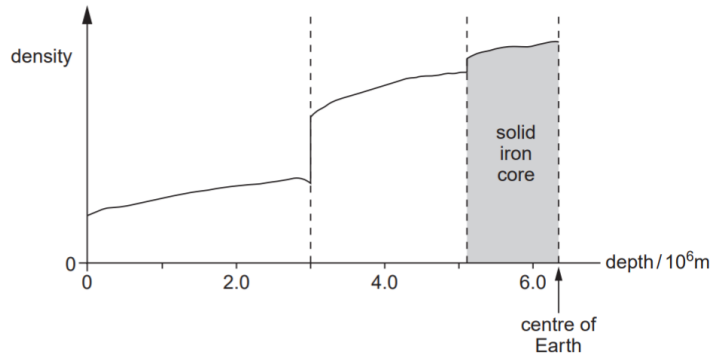

- i) Suggest how Fig. 2.1 shows that the Earth consists of a number of distinct layers.
- ii) Geophysicists believe that the central core of the Earth is solid iron. This central core is surrounded by a layer of molten metal. The central core starts at a depth of $5.1 \times 10^6 \text{ m}$. The solid iron core accounts for 18% of the mass of the Earth. The mass of the Earth is $6.0 \times 10^{24} \text{ kg}$ and its radius is $6.4 \times 10^6 \text{ m}$. Calculate the mean density of the central core of the Earth.

$$\text{Volume of a sphere} = \frac{4}{3}\pi r^3$$

DENSITY

Exam Style Question 1:

Answers:

a) Define density.

Density is the mass per unit volume.

bi) Suggest how Fig. 2.1 shows that the Earth consists of a number of distinct layers.

Dramatic changes in density at depths of $3.0 \times 10^6 \text{ m}$ and $5.1 \times 10^6 \text{ m}$.

bii) Calculate the mean density of the central core of the Earth.

$$\text{Density} = \frac{\text{mass}}{\text{volume}}$$

Mass of the central core:

$$\text{mass}_{\text{central core}} = 18\% \text{ of the mass of the Earth}$$

$$\text{mass}_{\text{central core}} = 18\% \times 6.0 \times 10^{24} \text{ kg}$$

$$\text{mass}_{\text{central core}} = 1.08 \times 10^{24} \text{ kg}$$

Radius of the solid iron core (r):

r = Radius of the Earth – where the central core starts

$$r = 6.4 \times 10^6 \text{ m} - 5.1 \times 10^6 \text{ m}$$

$$r = 1.3 \times 10^6 \text{ m}$$

Volume of the soft iron core:

$$V = \frac{4}{3}\pi r^3 = \frac{4}{3}\pi(1.3 \times 10^6)^3 = 9.20 \times 10^{18} \text{ m}^3$$

Density of the central core:

$$\text{Density} = \frac{1.08 \times 10^{24} \text{ kg}}{9.20 \times 10^{18} \text{ m}^3} = 117355.9435 \text{ kg m}^{-3}$$

Therefore, the mean density of the central core of the Earth is $1.2 \times 10^5 \text{ kg m}^{-3}$.



PRESSURE

Exam Style Question 2:

a) A block of concrete rests on the ground, as shown in Fig. 7.1

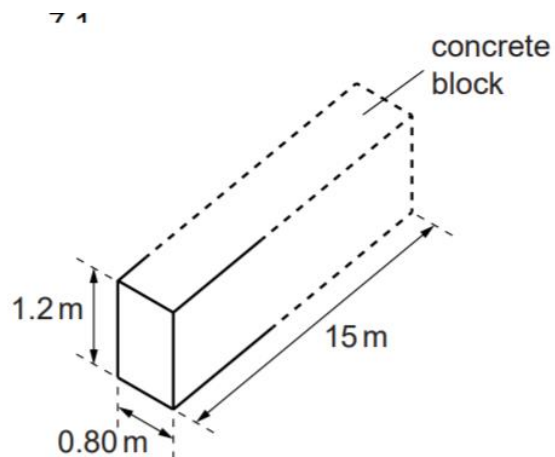

Fig. 7.1

The concrete block is 15 m long, 0.80 m wide and 1.2 m high. The density of concrete is $2.4 \times 10^3 \text{ kg m}^{-3}$. Calculate

- The weight of the concrete,
- The pressure exerted on the ground by the block of concrete.

PRESSURE

Exam Style Question 2:

Answer:

ai) The weight of the concrete.

$$\text{Density} = \frac{\text{mass}}{\text{volume}}$$

$$\therefore \text{mass} = \text{density} \times \text{volume of the concrete block}$$

$$\text{mass} = 2400 \text{ kg m}^{-3} \times (0.80 \text{ m} \times 1.2 \text{ m} \times 15 \text{ m})$$

$$\text{mass} = 34560 \text{ kg}$$

$$W = mg$$

$$W = 34560 \text{ kg} \times 9.81 \text{ m s}^{-2}$$

$$W = 339033.6 = 3.4 \times 10^5 \text{ N}$$

aii) the pressure exerted on the ground by the block concrete.

$$P = \frac{F}{A}$$

Here the only force acting is due to the weight of the concrete block which acts downwards and on the ground. The area in contact with the ground is just the bottom face of the concrete block ($15 \text{ m} \times 0.80 \text{ m}$), therefore:

$$P = \frac{3.46 \times 10^5 \text{ N}}{(15 \text{ m} \times 0.80 \text{ m})}$$

$$P = 2.8 \times 10^4 \text{ Pa}$$



Please see **'3.6.1 Density and Pressure notes'**
pack for revision notes.

For more revision notes, tutorials, worked
examples and more help visit
www.tutorpacks.co.uk.

